

Recommended Practice for Installing

# Aluminum Building Wire and Cable

NEIS



Published by  
National Electrical  
Contractors Association



Jointly developed with  
The Aluminum Association



**NECA 104-2006**

Recommended Practice for  
Installing Aluminum Building  
Wire and Cable

**An American  
National Standard**



Published by  
National Electrical  
Contractors Association



Jointly developed with  
The Aluminum Association



## NOTICE OF COPYRIGHT

*This document is copyrighted by NECA*

Reproduction of these documents either in hard copy or soft (including posting on the web) is prohibited without copyright permission. For copyright permission to reproduce portions of this document, please contact NECA Standards & Safety at (301) 657-3110 ext. 546, or send a fax to (301) 215-4500.

OR

National Electrical Contractors Association  
3 Bethesda Metro Center, Suite 1100  
Bethesda, Maryland 20814  
(301) 657-3110

Organizations may obtain permission to reproduce a limited number of copies by entering into a license agreement. For information, contact:

Global Engineering Documents  
15 Iverness Way East  
Englewood, CO 80112-5704 or call  
1-800-854-7179 (USA and Canada)  
(303) 397-7956 (International)

# Table of Contents

- Foreword** .....v
  
- 1. Scope** .....1
  - 1.1 Products and Applications Included .....1
  - 1.2 Products and Applications Excluded .....1
  - 1.3 Regulatory and Other Requirements .....1
  
- 2. Basic Installation Techniques** .....2
  - 2.1 General .....2
  - 2.2 Stripping Insulation .....2
  - 2.3 Connecting Aluminum Conductors .....2
  - 2.4 Pulling Aluminum Conductors in Conduits and Raceways .....3
  - 2.5 Installing Aluminum Cables in Trays and Racks .....4
  - 2.6 Minimum Bending Radii .....4
  - 2.7 Junction and Pull Boxes .....4
  
- 3. General Product Information** .....6
  - 3.1 Connector Types .....6
  - 3.2 Joint Compound .....8
  - 3.3 Terminal Lugs .....8
  - 3.4 Connecting Aluminum Conductors to Cooper Terminal Lugs .....10
  
- 4. Service Entrances Using Aluminum Cables** .....13
  - 4.1 Commercial/Industrial .....13
  - 4.2 Residential .....13
  
- 5. Designing with Aluminum** .....14
  - 5.1 General .....14
  - 5.2 Aluminum Conductor Ampacities and Sizes .....14
  - 5.3 Conduit Fill Requirements .....14
  - 5.4 Voltage Drop Considerations .....14
  - 5.5 Temperature Conditions .....14
  - 5.6 Moisture Conditions .....15
  
- 6. Type AC Aluminum Cables** .....21
  - 6.1 AC Cable Construction .....21
  - 6.2 AC Cable Applications .....22
  - 6.3 AC Cable Terminations .....22
  - 6.4 AC Cable Supports .....22

6.5	Fishing AC Cable .....	.22
6.6	AC Cable Grounding .....	.22
6.7	AC Cable Ampacities .....	.23
<b>7.</b>	<b>Type MC Cables .....</b>	<b>.24</b>
7.1	MC Cable Construction .....	.24
7.2	MC Cable Applications .....	.24
7.3	MC Cable Fittings .....	.24
7.4	MC Cable Supports .....	.24
7.5	MC Cable Grounding .....	.24
7.6	MC Cable Ampacities .....	.26
7.7	MC Cable Bending Radius .....	.26
<b>Annex A:</b>	<b>Reference Standards .....</b>	<b>.27</b>

*(This foreword is not a part of the standard)*

# Foreword

*National Electrical Installation Standards™* are designed to improve communication among specifiers, purchasers, and suppliers of electrical construction services. They define a minimum baseline of quality and workmanship for installing electrical products and systems. *NEIS™* are intended to be referenced in contract documents for electrical construction projects. The following language is recommended:

Aluminum building wire and cable shall be installed in accordance with NECA/AA 104, *Recommended Practice for Installing Aluminum Building Wire and Cable* (ANSI).

Use of *NEIS™* is voluntary, and neither the National Electrical Contractors Association nor The Aluminum Association assume any obligation or liability to users of this publication. Existence of a standard shall not preclude any member or nonmember of either organization from specifying or using alternate construction methods permitted by applicable regulations.

This publication is intended to comply with the edition of the National Electrical Code® (NEC) in effect at the time of publication. Because they are quality standards, *NEIS* may in some cases go beyond the minimum safety requirements of the NEC. It is the responsibility of users of this publication to comply

with state and local electrical codes when installing electrical products and systems.

Suggestions for revisions and improvements to this standard are welcome. They should be addressed to:

NECA Codes and Standards  
3 Bethesda Metro Center, Suite 1100  
Bethesda, MD 20814  
(301) 215-4521 telephone  
(301) 215-4500 fax  
[neis@necanet.org](mailto:neis@necanet.org)  
[www.neca-neis.org](http://www.neca-neis.org)

To purchase *National Electrical Installation Standards™* contact the NECA Order Desk at (301) 215-4504 tel, (301) 215-4500 fax, or [orderdesk@necanet.org](mailto:orderdesk@necanet.org).

Copyright© 2006, The Aluminum Association and National Electrical Contractors Association. All rights reserved. Unauthorized reproduction prohibited.

*National Electrical Installation Standards* and *NEIS* are trademarks of the National Electrical Contractors Association. National Electrical Code and NEC are registered trademarks of the National Fire Protection Association, Quincy, Massachusetts.

*Cover illustration courtesy of Alcan Cable*

*<This page intentionally left blank>*

# 1. Scope

This recommended practice describes installation procedures and design considerations for aluminum building wire and cable in residential, commercial, institutional and industrial applications not exceeding 600 volts.

## 1.1 Products and Applications Included

This publication covers aluminum alloy building wire and cable types RHH, RHW, RHW-2, THW, THW-2, THHN, THWN, THWN-2, XHHW and XHHW-2; and AC, MC, TC and SE.

## 1.2 Products and Applications Excluded

This publication does not cover aluminum alloy conductors used in electric utility applications.

## 1.3 Regulatory and Other Requirements

a) All information in this publication is intended to comply with the National Electrical Code (NFPA 70). Installers should always follow the NEC, applicable state and local codes, and manufacturers' instructions when installing aluminum building wire and cable.

Only qualified persons as defined in the NEC who are familiar with the installation of aluminum build-

ing wire and cable should perform the work described in this publication. Administrative and other tasks can be performed under the supervision of a qualified person.

Other *National Electrical Installation Standards* provide guidance for installing additional types of electrical products and systems. A complete list of *NEIS* is provided in Annex A.

# 2. Basic Installation Techniques

## 2.1 General

Installation procedures for aluminum alloy building wire products are typical of the procedures required for electrical wire and cable products.

## 2.2 Stripping Insulation

- a) One way to remove insulation is to pencil or whittle it (*Figure 1*). Another method is to skin the insulation back from the cut end of the conductor and then cut outward (*Figure 2*).
- b) A quicker and easier way is to use one of the several types of insulation strippers that are available to remove insulation. *Figure 3* shows a type useful for popular sizes of conductors (6 AWG through 1000 kcmil).
- c) Do not “ring cut” the insulation from a conductor or cable, using knife or pliers. Doing so can nick or damage the conductors inside.

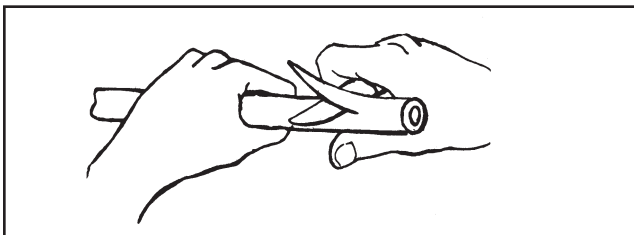

Figure 1

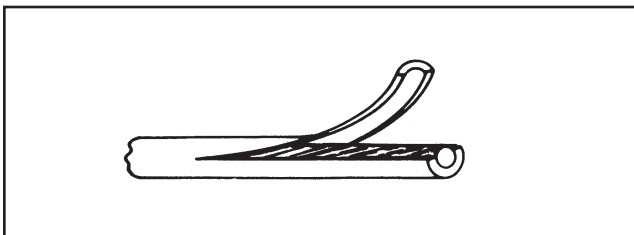

Figure 2

## 2.3 Splicing Aluminum Conductors

Aluminum conductors should be spliced using connectors as described in 3.1.

### 2.3.1 Underground connections

Typically, compression-type connectors are used for underground applications. A splice box may or may not be required for these connections. Follow these steps to splice aluminum conductors using compression-type connectors:

- a) Strip the insulation from the end of each conductor. Strip back far enough so the conductor will go fully into the connector, but also make sure the insulation fits closely to the connector. Wire-brush the stripped conductor.
- b) Insert the stripped end of the conductor into the connector as far as it will go. Typically, manufacturers supply these connectors filled with joint compound to seal the splice against moisture and other contaminants.

- c) Apply the crimping tool designed for that type of connector and crimp fully in accordance with the manufacturer's instructions (*Figure 4*). Be sure to select the correct crimping tool die for the size of the connector and the conductor being spliced.

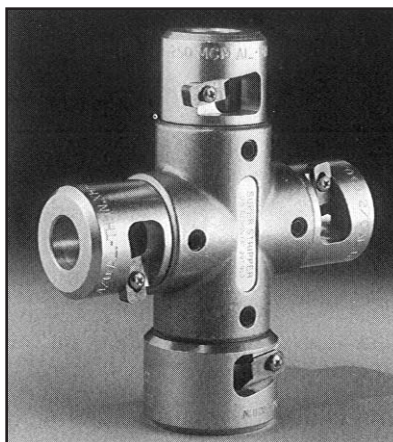

Figure 3

d) Wipe off any excess joint compound and insulate the connection using tape, heat or cold-shrinkable tubing or other approved insulating material.

### 2.3.2 Above-ground connections

Both compression-type and screw-type connectors are used for above-ground applications.

*Compression-type connections* are typically made inside a splice box. Size the box to accommodate the number of conductors and connectors. Follow the instructions in 3.1.2.1 for installing compression-type connectors.

*Screw-type connections* are typically made inside junction boxes with built-in terminal strips; these are supplied as an integral part of equipment such as motors and transformers. Install mechanical screw-type terminal lug connectors as described in 3.1.2.1. Install compression-type terminal lug connectors as described in 3.1.2.2.

## 2.4 Pulling Aluminum Conductors in Conduits and Raceways

Follow these steps to install aluminum conductors in conduits and raceways:

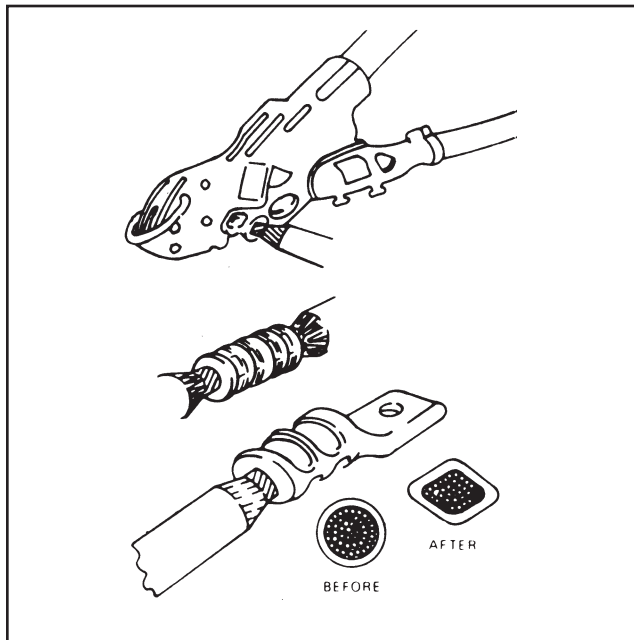

Figure 4

a) Be sure that the raceway is sized in accordance with the requirements of the NEC.

b) Run a “fish” line through the conduit.

(NOTE: Attaching the line to a piston-type device, which is propelled through the conduit by compressed air, can do this. Another method is to push a round flexible speedometer type steel wire through the conduit. Polyethylene fish tapes can be used for shorter runs up to about 100 feet or 30.5 meters.)

c) Attach a clean-out brush to the fish line and behind it attach the pull line. Then pull both through the conduit by means of the fish line.

d) Where appropriate, use a basket grip over the insulation to attach the pull line to the conductor or conductors (Figure 5).

e) Where conductors are pulled with a rope, stagger the conductor ends and anchor in position with tape, to provide maximum flexibility around bends (Figure 6).

f) Where possible, feed conductors into the conduit end closest to the sharpest bend, to reduce pulling tension.

g) To avoid unduly stressing the conductors, ensure that pulling equipment is of adequate power to provide a steady tension on the cables and avoid jerks.

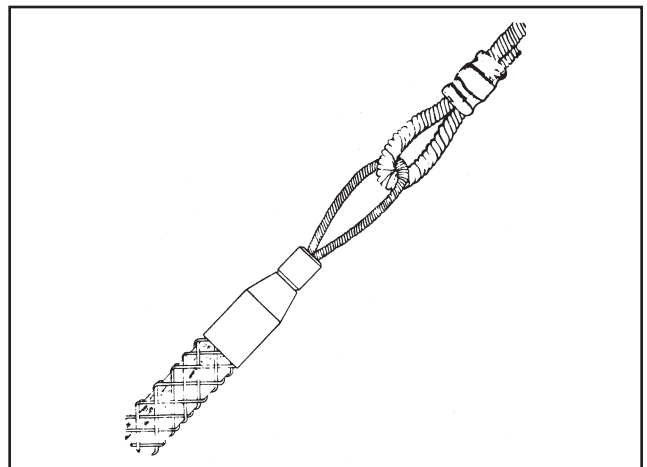

Figure 5

- h) Use pulling compound compatible with the conductor insulation as the conductors are fed into the raceways, to reduce friction and required pulling tension.
- i) Wherever possible, when feeding multiple conductors or cables into a conduit or raceway, stagger the reels one behind the other so as to maintain equal pulling tensions, and prevent conductor or cable cross-over and jamming in the conduit.
- j) Where possible, pull conductors in a downward direction, to allow gravity to assist in pulling with reduced tension.

## 2.5 Installing Aluminum Cables in Trays and Racks

Where conductors and cables are to be installed in trays or cable racks, follow the applicable steps in Section 2.3, plus the following:

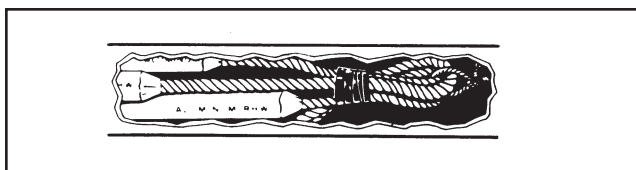

Figure 6

- a) Follow the requirements of NEC Article 392 to determine the allowable number of wires or cables permitted in trays and their respective ampacities. To be suitable for use in cable trays, the conductors and cables are required to meet the requirements for and bear the marking “For CT Use.” Except as permitted in the NEC, single conductors installed by cable trays are required to be 1/0 AWG and larger.

*(NOTE: Although the conductors used in cable trays may have a higher ampacity than the same conductors installed in raceways, it is generally not possible to utilize the higher ampacities for two reasons. First, the conductors installed in the trays generally end up in a raceway, which limits the rated ampacity of the circuit. Second, equipment rated for up to 600 Volts is evaluated using ampacities from the 75°C column of NEC Table 310.16 in accordance with Section 110.14 and applicable UL standards.)*

- b) Where pulling attachments are used on cables, cover them with rubber or plastic tapes to prevent scoring of the trays and installation sheaves during the pulling operation.
- c) Use large-radius sheaves around bends and smaller sheaves on the straight sections of cable support

**Table 2** **Bending Radii\***  
**For 600 V Cable Not in Conduit, on Sheaves or While Under Tension**  
**(Power Cables Without Metallic Shielding or Armor)**

The minimum recommended bending radii as multiple of the overall cable diameter given in the following tabulation are for both single and multi-conductor cable with or without lead sheath and without metallic shielding or armor.

Thickness of Conductor Insulation inches (mm)	Minimum Bending Radius ** as multiple of cable diameter Overall Diameter of Cable - inches (mm)		
	1.000 (25.4) and less	1.001 to 2.000 (25.4 to 50.8)	2.001 (50.8) and over
0.169 (4.31) and less	4	5	6
0.170 to 0.310 (4.32 to 7.87)	5	6	7
0.311 (7.88) and over	-	7	8

\* ICEA S-66-524/NEMA WC 7

\*\* The minimum bending radius under tension may be larger depending on projected bearing pressures.

trays, to reduce the required pulling tensions and to prevent damage to the wires or cables.

d) Where wires or cables are anchored to trays, be sure straps or other cable anchoring devices do not cut into the insulation or jacket.

e) Straight cable tray runs can often be installed by simply laying the cables in place.

(NOTE: Split-bolt connectors are listed for two-conductor connections; a terminal block should be used for connecting multiple conductors.)

## 2.6 Minimum Bending Radii

Bends should be made *before* the terminal or connector is applied to the cable, to minimize electrical contact distortion. Recommended minimum bending radii based on the outside diameter (OD) of insulated conductors are given in Table 2.

## 2.7 Junction and Pull Boxes

Junction boxes and pull boxes should be used wherever:

a) Conductors change direction to provide for thermal expansion and contraction of conductors.

(NOTE: This does not apply to smooth bends made in conduits or continuous runs of cables.)

b) Tap connections are made (Figure 7).

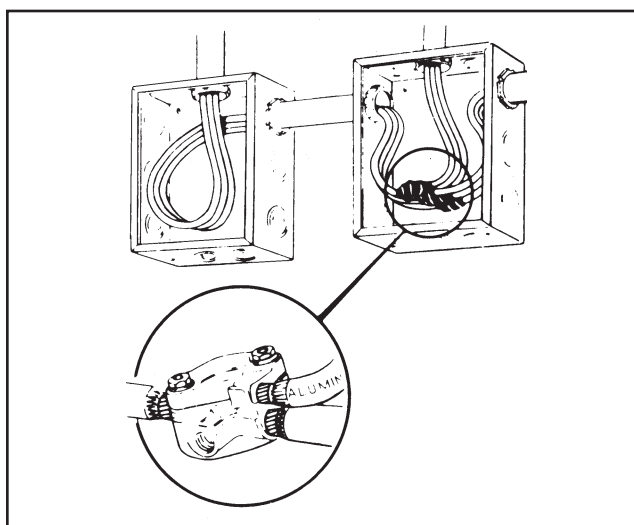

Figure 7

# 3. Connection Techniques for Aluminum Conductors

## 3.1 Connector Types

Pressure-type connectors for use with aluminum conductors come in two basic types:

- Mechanical screw-type
- Compression-type applied with a tool and die

Both types are designed to apply sufficient pressure to provide low resistance metal to metal contact. The connectors are usually plated to avoid oxidation and to resist corrosion. Most compression connectors are supplied by the manufacturers already filled with joint compound to seal the connection from moisture and other contaminants.

Pressure-type connectors are available in many configurations; Figure 8 shows some typical connectors.

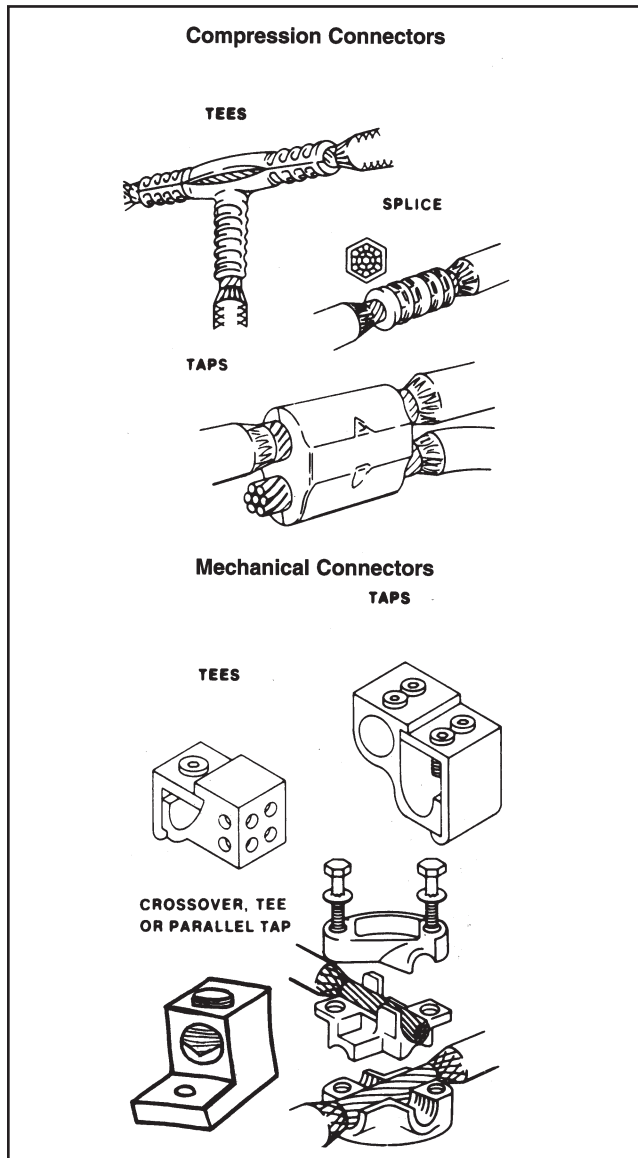

Figure 8

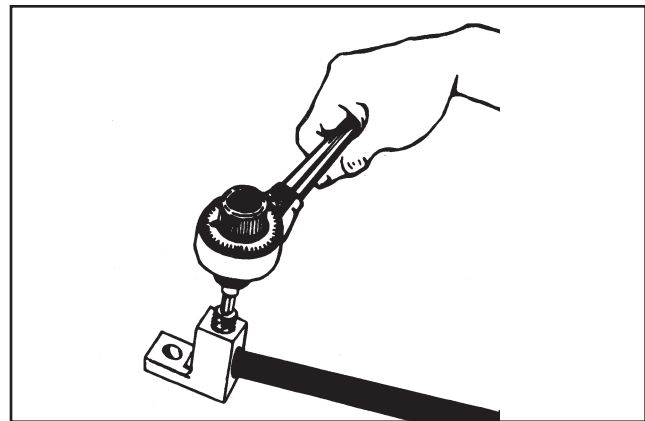

Figure 9

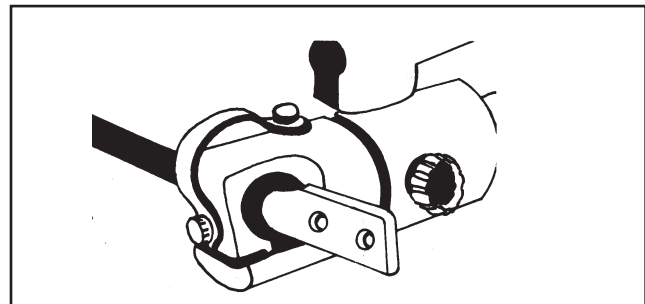

Figure 10

**3.1.1 Listing and marking**

Pressure-type connectors listed for use with both aluminum and copper conductors are marked AL7CU or AL9CU (or CU7AL or CU9AL).

*(NOTE: Pressure-type connectors rated for 6 AWG or smaller conductors may have the markings on the connector, the unit container, or an information sheet packed in the unit container. Also, The AL7CU or AL9CU marking is not required on equipment connectors. However, the equipment bears a marking, such as AL-CU, indicating that they are suitable for both aluminum and copper conductors.)*

Connectors listed for use with aluminum conductors are listed in the UL Electrical Construction Equipment Directory. The category name for these connectors is “Wire Connectors and Soldering Lugs (ZMVV).”

**3.1.2 Installation procedure – mechanical screw-type connectors**

Follow these general procedures to install connectors (Figure 9). All manufacturers’ instructions should also be followed:

a) Use listed AL7CU or AL9CU connectors sized to accept aluminum conductors of the ampacity specified.

b) Using a suitable stripping tool, to avoid damage to the conductor, remove insulation from the required length of the conductor.

c) Wire brush the conductor and apply a Listed joint compound.

d) Tighten the connection per the connector manufacturer’s recommendation. In absence of specific recommendations, use the torque values shown in Tables 3.1, 3.2, and 3.3.

e) Wipe off any excess joint compound.

**3.1.3 Installation procedures – compression-type connectors**

Follow these general procedures to install connectors (Figure 10). All manufacturers’ instructions should also be followed:

a) Use listed AL7CU or AL9CU connectors sized to accept aluminum conductors of the ampacity specified.

b) The lugs should be marked with wire size, die index, number and location of crimps and should be suitably color coded. Lug barrel should be factory pre-filled with a Listed joint compound.

**Table 3.1 Tightening Torque for Slotted Head Screws  
Smaller than No. 10 Intended for Use With 8 AWG or Smaller Conductors**

Slot Length of Screw	Tightening Torque, Pound-Inches (N-m)		
	Slot Width of Screw Smaller Than 0.047 Inch (1.2 mm)	Slot Width of Screw 0.047 Inch (1.2 mm) and Larger,	
Inch (mm)	Inch (mm)	Inch (mm)	
Less than	5/32 (4)	7 (0.79)	9 (1.0)
	5/32 (4)	7 (0.79)	12 (1.4)
	3/16 (4.8)	7 (0.79)	12 (1.4)
	7/32 (5.6)	7 (0.79)	12 (1.4)
	1/4 (6.4)	9 (1.0)	12 (1.4)
	9/32 (7.1)	15 (1.7)	
Above	9/32 (7.1)	20 (2.3)	

- c) Using a suitable stripping tool, to avoid damage to the conductor, remove insulation from the required length of the conductor.
- d) Wire brush the conductor.
- e) Crimp the connection per connector manufacturer's recommendations.
- f) Wipe off any excess joint compound.
- g) If required, tape the joint as described in 2.3 or apply the insulating enclosure, if provided, with the connector.

### 3.2 Joint Compound

Conductor Termination Compounds (commonly known as joint compounds) are used on splice and termination connections of aluminum, copper-clad aluminum, and copper conductors where needed to retard oxidation at conductor/connector interface. Joint compounds are produced in many varieties, all with special properties appropriate for their intended use. Compound should be compatible with conductor insulation and components used for splicing and terminating. These compounds do not have a deleterious effect on the conductor metal, insulation or equipment when used in accordance with the manufacturer's installation instructions.

A Listed joint compound is applied to the bare conductor after it has been wire brushed. A coating of joint compound remains on the surface of the conductors, preventing the oxide from reforming when it is broken in the installation operation.

*(NOTE: Some joint compounds contain coarse grit or metallic particles, which make them unsuitable for flat-bar connections.)*

### 3.3 Terminal Lugs

Listed terminal lugs marked AL7CU or AL9CU are used to connect aluminum conductors to transformers, switches, bus bars, motors and other equipment. Aluminum terminals are usually plated to resist corrosion, and these plated connectors should not be wire brushed or abraded.

Like connectors, terminal lugs are of two basic types: mechanical screw type and compression type applied by tool and die. Figure 11 shows typical terminal lugs. They are applied to the conductor ends in the same manner described in 3.1.

Care should be taken that conductor temperature and ampacity ratings are compatible with the terminals and equipment to which they are to be connected. See the markings on the equipment, the instructions furnished with the equipment, or the installation instructions (drawings) for the project for these details.

#### 3.3.1 Installation procedure

When all components are aluminum (bus, studs, and lugs), aluminum bolts should be used to make the connections. Follow these steps:

- a) Use the components furnished or specified by the equipment manufacturer. These may include:
  - Aluminum bolts should be anodized alloy 2024-T4 and conform to ANSI B18.2.1 specifications and to ASTM B211 or B221 chemical and mechanical property limits.
  - Nuts should be aluminum alloy 6061-T6 or 6262-T9 and conform to ANSI B18.2.2.

Socket Size Across Flats		Tightening Torque, Pound-Inches (N-m)	
Inch	(mm)	Inch	(mm)
1/8	(3.2)	45	(5.1)
5/32	(4.0)	100	(11.3)
3/16	(4.8)	120	(13.6)
7/32	(5.6)	150	(16.9)
1/4	(6.4)	200	(22.6)
5/16	(7.9)	275	(31.1)
3/8	(9.5)	375	(42.4)
1/2	(12.7)	500	(56.5)
9/16	(14.3)	600	(67.8)

- Washers should be flat aluminum alloy 2024-T4, Type A plain, standard wide series conforming to ANSI B27.2. SAE or narrow series washers should not be used.

b) Hardware should be assembled as shown in Figure 12.

- Lubricate all hardware with silicon spray or other suitable lubricant before tightening. If bolts are not lubricated, torque may vary widely and result in high contact resistance at joints.
- Tighten bolts to the manufacturer’s recommended torque. In the absence of specific recommendations, use the torque values shown in Table 3.4.

### 3.4 Connecting Aluminum Conductors to Copper Terminal Lugs

Two methods can be used to connect aluminum conductors to equipment in an existing installation with copper bus bar or studs, or when equipment is not supplied with terminations suitable for aluminum conductors.

(NOTE: Consult the authority having jurisdiction for approvals required, if any, prior to the installation.)

#### 3.4.1 Bolted connection

A steel bolt should be used with a Belleville conical spring washer to allow for the differing rates of thermal expansion of the materials. Belleville washer sizes are shown in Table 4.

**Table 3.3 Tightening Torque for Screws<sup>a</sup>**

Test Conductor Size Installed in Connector	Tightening Torque, Pound-Inches (N-m)								
	Slotted Head No. 10 and Larger				Hexagonal Head — External Drive Socket Wrench				
	Slot Width — 0.047 Inch (1.2 mm) or Less and Slot Length — 1/4 Inch (6.4 mm) or Less		Slot Width — Over 0.047 Inch (1.2 mm) or Slot Length — Over 1/4 Inch (6.4 mm)		Split-Bolt Connectors		Other Connectors		
AWG or kcmil	(mm <sup>2</sup> )	Inch	(mm)	Inch	(mm)	Inch	(mm)	Inch	(mm)
30 - 10	(0.05-5.3)	20	(2.3)	35	(4.0)	80	(9.0)	75	(8.5)
8	(8.4)	25	(2.8)	40	(4.5)	80	(9.0)	75	(8.5)
6 - 4	(13.2-21.2)	35	(4.0)	45	(5.1)	165	(18.6)	110	(12.4)
3	(26.7)	35	(4.0)	50	(5.6)	275	(31.1)	150	(16.9)
2	(33.6)	40	(4.5)	50	(5.6)	275	(31.1)	150	(16.9)
1	(42.4)	----	----	50	(5.6)	275	(31.1)	150	(16.9)
1/0-2/0	(53.5-67.4)	----	----	50	(5.6)	385	(43.5)	180	(20.3)
3/0-4/0	(85.0-107.2)	----	----	50	(5.6)	500	(56.5)	250	(28.2)
250-350	(127-177)	----	----	50	(5.6)	650	(73.4)	325	(36.7)
400	(203)	----	----	50	(5.6)	825	(93.2)	325	(36.7)
500	(253)	----	----	50	(5.6)	825	(93.2)	375	(42.4)
600-750	(304-380)	----	----	50	(5.6)	1000	(113.0)	375	(42.4)
800-1000	(406-508)	----	----	50	(5.6)	1100	(124.3)	500	(56.5)
1250-2000	(635-1010)	----	----	50	(5.6)	1100	(124.3)	600	(67.8)

Bolt Diameter (inch)	Tightening Torque (pound-feet)
1/4 or less	6
5/16	11
3/8	19
7/16	30
1/2	40
5/8 or more	55

a) Use the components furnished or specified by the equipment manufacturer. These may include:

- Steel bolts should be plated or galvanized, medium carbon steel, heat treated, quenched and tempered equal to ASTM A-325 or SAE grade 5.
- Nuts should be heavy semi-finished hexagonal, conforming to ANSI B18.2.2, with unified coarse series (U.C.) threads, class 2B.
- Flat washers should be steel, Type A, plain standard wide series conforming to ANSI B27.2. SAE or narrow series washers should not be used.
- Hardware should be assembled as shown in Figure 13.

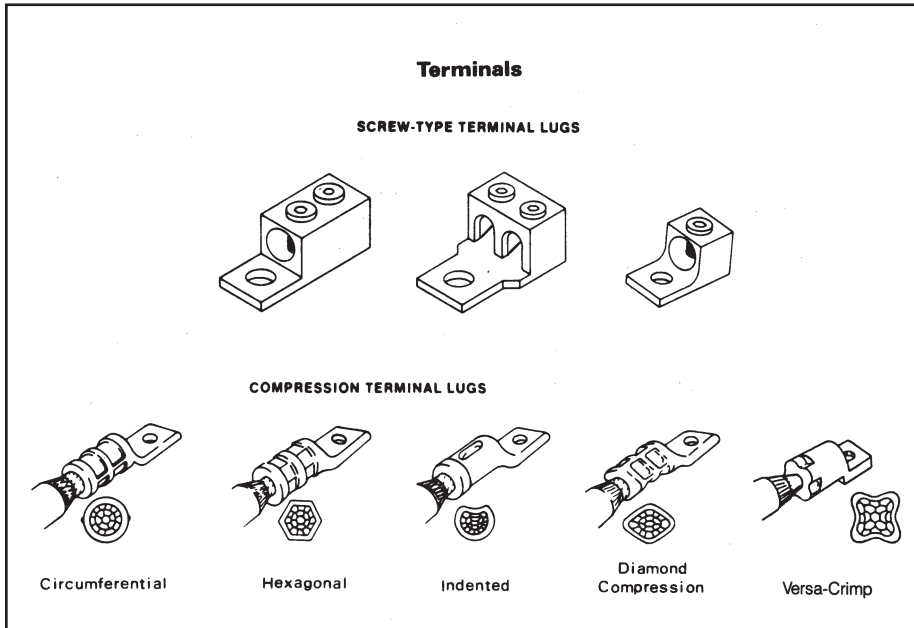

Figure 11

- All hardware should be lubricated with silicon spray or other suitable lubricant before tightening.

b) Tighten bolts to the equipment manufacturer's recommended torque.

### 3.4.2 Gutter splice

A "gutter splice" may be used to connect the aluminum conductor. The aluminum conductor is spliced to a short length of copper conductor using an AL7CU or AL9CU compression type connector as shown in Figure 14. The copper conductor stub is then connected to the equipment terminal. Where it is not practical to use a gutter splice, use one of the following methods:

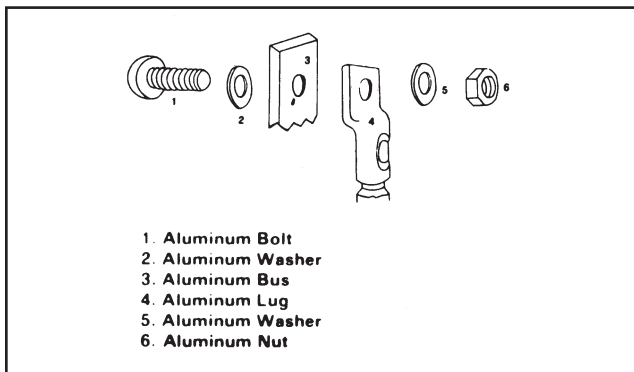

Figure 12

connected to the equipment terminal. Where it is not practical to use a gutter splice, use one of the following methods:

- a) Use listed AL7CU or AL9CU adapter fittings specifically designed for this purpose (Figure 16), or
- b) Use large compression type lugs, preferably with two holes, to connect large aluminum conductors (500 kcmil and up) to heavy equipment having copper terminal studs and/or pads.

- When using aluminum bolts and nuts, only a heavy flat washer, bearing on the aluminum lug is necessary as shown in Figure 15, or
- With other than aluminum bolts, use Belleville spring washers and heavy flat washers arranged as shown in Figure 13.

Figures 17-21 show typical connections of aluminum

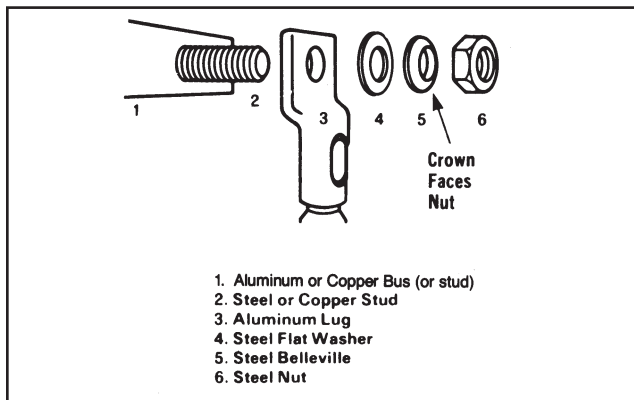

Figure 13

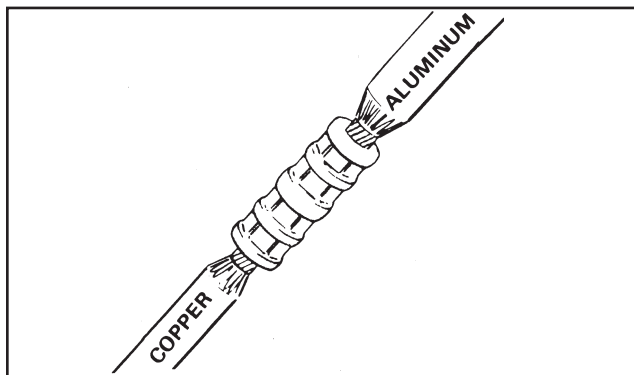

Figure 14

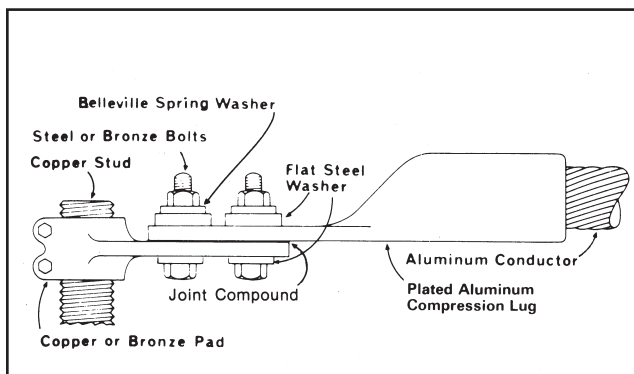

Figure 15

conductors to equipment terminal lugs in similar situations.

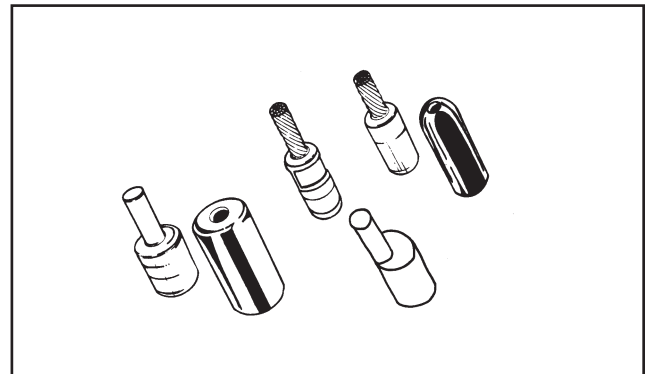

Figure 16

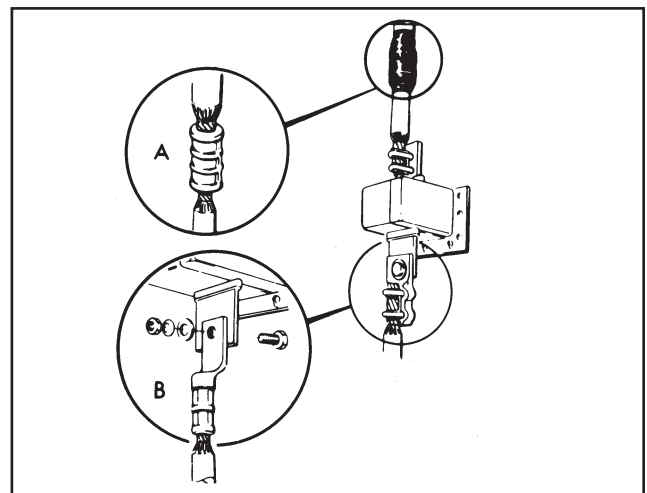

Figure 17

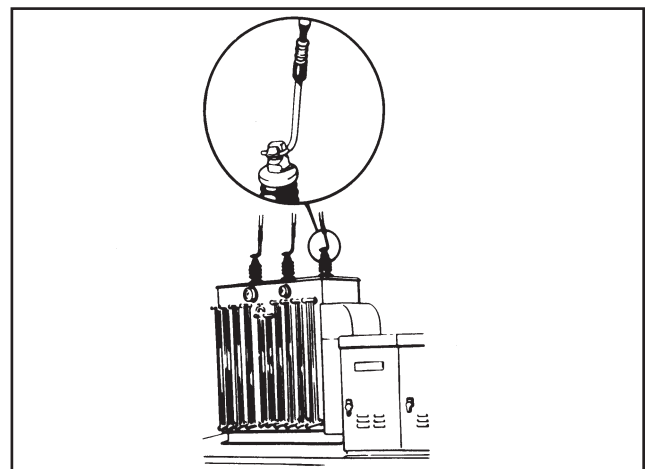

Figure 18

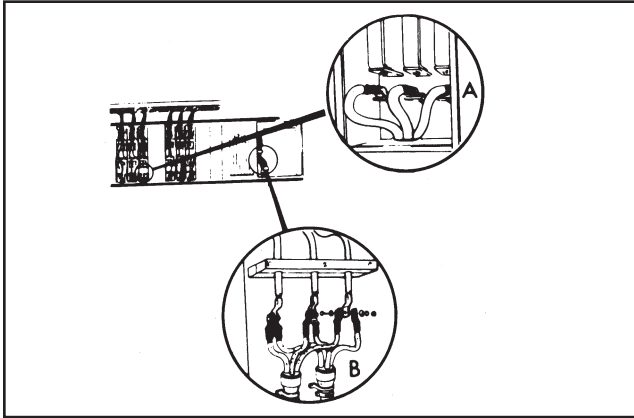

Figure 19

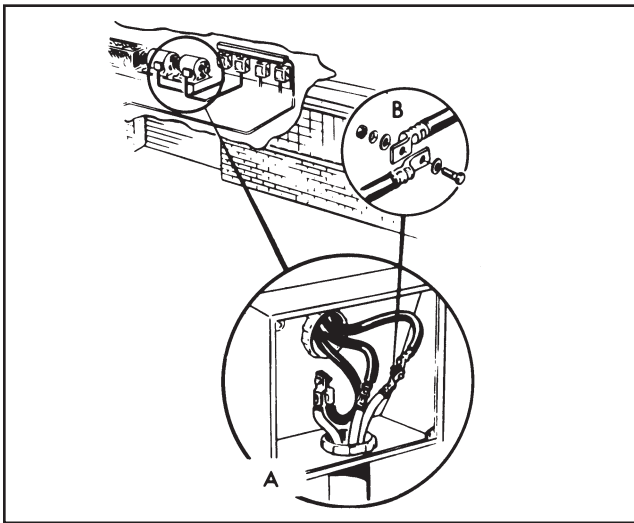

Figure 20

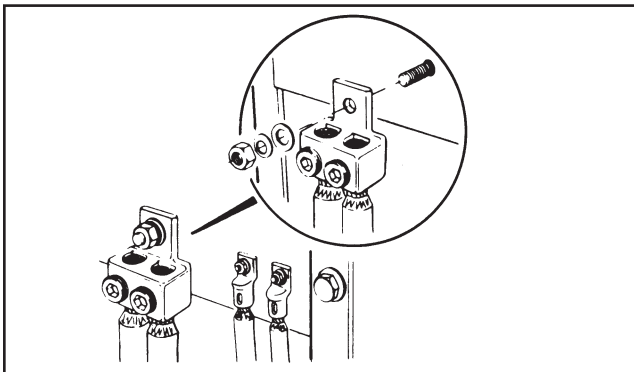

Figure 21

# 4. Service Entrances Using Aluminum Cables

## 4.1 Commercial/Industrial

Aluminum service entrance conductors are spliced to aluminum service drop cable as described in 2.3. Aluminum service entrance conductors should be spliced to copper service drop cables using listed adapter connectors.

Bare aluminum conductors are permitted for system grounding by NEC Article 250. Listed ground clamps for use with aluminum grounding electrode conductors are marked AL or AL-CU. There is no temperature rating associated with grounding clamps. Therefore, a “7” or “9” is not included in the marking on the clamps.

Equipment grounding conductors of bare or insulated aluminum or copper-clad aluminum are permitted by NEC Article 250 for installations in raceways or as a part of an assembly of cable construction. Where used, these conductors shall not come in direct contact with masonry or the earth or where subject to corrosive conditions. Where terminated outside, these conductors shall not be installed within 18 inches (460 mm) of the earth.

Figure 22 shows a typical medium-size service entrance.

## 4.2 Residential

Type SE aluminum cable is used for residential service entrances. It is connected to the utility service drop cable as described in 4.1.

Meter boxes and electrical panels are available with aluminum AL7CU or AL9CU terminals for connection to Type SE aluminum service entrance cable.

Figure 23 shows typical applications for Type SE Style U and Style R service entrance cables in accordance with the NEC.

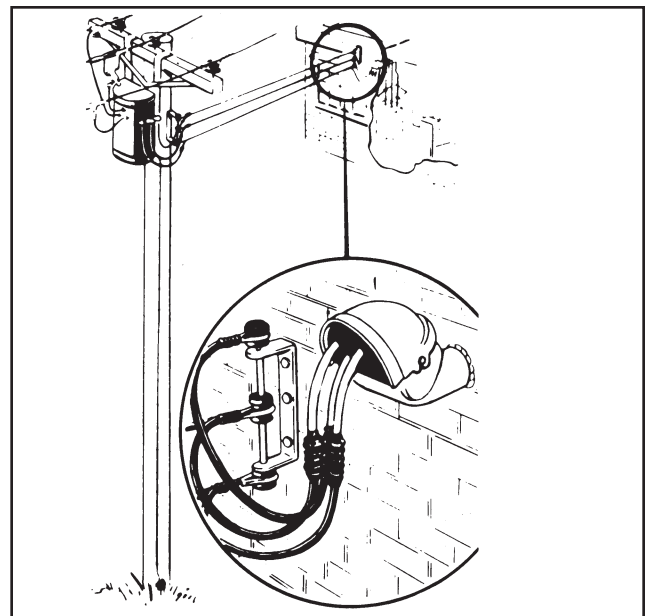

Figure 22

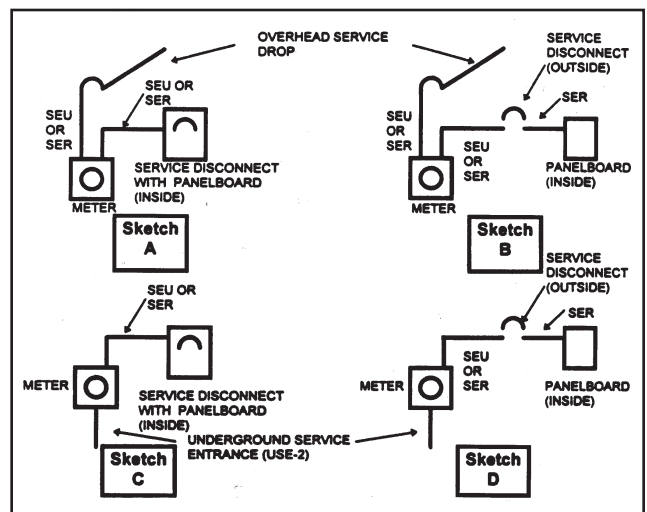

Figure 23

# 5. Designing with Aluminum

## 5.1 General

Design procedures for aluminum alloy building wire products are typical of the procedures required for electrical wire and cable products. It is recommended to verify that the choice of aluminum conductors is included in the design of an installation.

## 5.2 Aluminum Conductor Ampacities and Sizes

Table 5.1 lists ampacities of aluminum and copper-clad aluminum conductors.

Table 5.2 lists sizes of aluminum and copper-clad aluminum conductors permitted for 120/240 volt, 3-wire, single-phase dwelling services and feeders.

*NOTE: Using large-size single conductors for feeders sometimes results in excessive conductor and conduit cost. The use of smaller conductors in parallel to provide the required ampacity often proves more efficient.*

## 5.3 Conduit Fill Requirements

Table 5.3 provides the nominal conductor dimensions for compact stranded aluminum alloy conductors. Based on these dimensions, Tables C1A through C12A of NEC Appendix C provide the maximum number of compact aluminum alloy building wire conductors that can be installed in various types of conduits. For example, Table 5.4 shows maximum number of compact stranded conductors permitted in electrical metallic tubing (EMT).

In most cases, there is no need to change the size of a raceway from that needed for copper conductors when using electrically equivalent size of compact stranded aluminum alloy building wire conductors.

*(NOTE: Since copper conductors are generally made using compressed or concentric stranded construction and aluminum alloy building wire conductors are generally made using compact stranded construction, the overall diameter of compact stranded electrically equivalent aluminum conductors is comparable to the copper conductors.)*

## 5.4 Voltage Drop Considerations

Voltage drop is an important element in the design of an electrical installation. The NEC recommends limiting voltage drop to 3 percent for either branch circuits or feeders, and 5 percent for feeders and branch circuits together.

Table 5.5 lists voltage drop for aluminum building wire in sizes for 12 AWG to 1000 kcmil, at power factors ranging from 70 to 100 percent. Table 5.6 lists resistances of aluminum conductors. Table 5.7 lists inductive reactance in magnetic and non-magnetic conduits, thus making it possible to calculate voltage drops.

## 5.5 Temperature Conditions

The NEC gives derating factors for ambient temperatures above 30°C (86°F).

In general, operation at high conductor temperatures should be avoided. Voltage drop problems introduced by higher resistances in aluminum and copper-clad aluminum conductors at higher operating temperature outweigh the advantage of slightly higher current carrying capacity ampacity permitted by the higher temperature rating of the conductor.

It should be noted that equipment rated up to 600 volts is evaluated using ampacities from NEC Table 310.16 (60°C or 75°C column) in accordance with 110.14 and applicable UL standards. Thus, the ampacities of conductors suitable for operation at

90°C may be used to perform the applicable derating calculations such that the resulting ampacity of the conductors is not greater than their ampacity at 60° or 75°C to match the temperature rating of the equipment.

### 5.6 Moisture Conditions

Properly installed aluminum cables and conductors will operate satisfactorily in damp and wet locations. In these locations, Type THW, XHHW, or THWN insulated wires are the preferred choices. Joint compound should always be used when making connections in these locations.

**Table 5.1 Allowable Ampacities of Insulated Aluminum and Copper-Clad Aluminum Conductors Rated 0 through 2000 Volts, 60° to 90°C (140° to 194°F) Based on 30°C (86°F) Ambient Temperature**

Size AWG or kcmil	Not More Than Three Conductors in a Raceway or Cable or Earth (Directly Buried)			Single Conductor in Free Air		
	60°C Rating	75°C Rating	90°C Rating	60°C Rating	75°C Rating	90°C Rating
	TW	THW THWN RHW XHHW	THW-2 THHN THWN-2 RHH RHW-2 XHHW-2	TW	THW THWN RHW XHHW	THW-2 THHN THWN-2 RHH RHW-2 XHHW-2
	Alum.	Alum.	Alum.	Alum.	Alum.	Alum.
12	†20	†20	†25	††25	††30	††35
10	25	30	†35	††35	††40	††40
8	30	40	45	45	55	60
6	40	50	60	60	75	80
4	55	65	75	80	100	110
3	65	75	85	95	115	130
2	75	**90	**100	110	135	150
1	85	**100	**115	130	155	175
1/0	100	**120	**135	150	180	205
2/0	115	**135	**150	175	210	235
3/0	130	**155	**175	200	240	275
4/0	150	**180	**205	235	280	315
250	170	**205	**230	265	315	355
300	190	**230	**255	290	350	395
350	210	**250	**280	330	395	445
400	225	270	305	355	425	480
500	260	**310	**350	405	485	545
600	285	**340	385	455	540	615
700	310	375	420	500	595	675
750	320	385	435	515	620	700
800	330	395	450	535	645	725
900	355	425	480	580	700	785
1000	375	445	500	625	750	845

†Unless otherwise specifically permitted in the NEC, the over-current protection for conductor types marked with an Obelisk(†) shall not exceed 15 amperes for 12 AWG and 25 amperes for 10 AWG aluminum and copper-clad aluminum after any correction factor for ambient temperature and number of conductors have been applied.

††Unless otherwise specifically permitted in the NEC, the overcurrent protection for conductor types marked with a double obelisk (††) shall not exceed 15 amperes for 12 AWG and 25 amperes for 10 AWG aluminum and copper-clad aluminum.

\*\*See Table 5.2.

**Table 5.2 120/240 Volt, 3-Wire, Single-Phase Dwelling Services and Feeders**

For individual dwelling units, conductors listed below shall be permitted to be utilized as 120/240 volt, 3-wire, single-phase service-entrance conductors, service lateral conductors, and feeder conductors that serve as the main power feeder to a dwelling unit and are installed in raceway or cable with or without an equipment grounding conductor. For this application, the main power feeder shall be the feeder(s) between the main disconnect and the lighting and appliance branch-circuit panelboard(s), and the feeder conductors to a dwelling unit shall not be required to be larger than their service-entrance conductors. The grounded conductor shall be permitted to be smaller than the ungrounded conductors, provided the requirements are met.

**Conductor Types and Sizes**

RH, RHH, RHW, RHW-2, THHN, THHW, THW, THW-2, THWN, THWN-2, XHHW, XHHW-2, SE, USE, USE-2

Aluminum or Copper-Clad Aluminum	Service or Feeder Rating in Amps
AWG	
2	100
1	110
1/0	125
2/0	150
3/0	175
4/0	200
250 kcmil	225
300 kcmil	250
350 kcmil	300
500 kcmil	350
600 kcmil	400

**Correction Factors for Room Temperatures over 30°C (86°F)**

°C	°F	60°C Rating	75°C Rating	90°C Rating
31-35	85-95	.91	.94	.96
36-40	97-104	.82	.88	.91
41-45	105-113	.71	.82	.87
46-50	114-122	.58	.75	.82
51-60	124-140		.58	.71
61-70	142-158		.35	.58
71-80	160-176			.41

**More than Three Current-Carrying Conductors in a Raceway or Cable.** Where the number of current-carrying conductors in a raceway or cable exceeds three, the allowable ampacities shall be reduced as shown in the following table:

Number of Current-Carrying Conductors	Percent of Values in Tables as Adjusted for Ambient Temperature if Necessary
4 through 6	80
7 through 9	70
10 through 20	50
21 through 30	45
31 through 40	40
41 and above	35

A neutral conductor, which carries only the unbalance current from other conductors as in the case of normally balanced circuits of three or more conductors, shall not be counted in determining ampacities as described above. In a 3-wire circuit, consisting of two phase wires and the neutral of a 4-wire, three-phase wye connected system, a common conductor carries approximately the same current as the other conductors and shall be counted in determining ampacities.

**Table 5.3 Nominal Dimensions<sup>1</sup>, Areas, and Mass/1000 ft. for Common Aluminum Building Wire**

Bare Conductor <sup>2</sup>		Type THHN, THWN-2, THWN <sup>2,3</sup>			Type XHHW-2, XHHW <sup>2,4</sup>			Size AWG or KCMIL
Size AWG or KCMIL	Dia. Inches	Approx. Dia. Inches	Approx. Area Sq. In.	Nominal Mass Lb./1000 ft.	Approx. Dia. Inches	Approx. Area Sq. In.	Nominal Mass Lb./1000 ft.	
8	.134	—	—	—	.224	.0394	28	8
6	.169	.240	.0452	37	.260	.0530	40	6
4	.213	.305	.0730	60	.305	.0730	60	4
2	.268	.360	.1017	90	.360	.1017	85	2
1	.299	.415	.1352	115	.415	.1352	110	1
1/0	.336	.450	.1590	140	.450	.1590	135	1/0
2/0	.376	.495	.1924	170	.490	.1885	165	2/0
3/0	.423	.540	.2290	210	.540	.2290	200	3/0
4/0	.475	.595	.2780	255	.590	.2733	245	4/0
250	.520	.670	.3525	310	.660	.3421	295	250
300	.570	.720	.4071	360	.715	.4015	350	300
350	.616	.770	.4656	415	.760	.4536	400	250
400	.659	.815	.5216	465	.800	.5026	450	400
500	.736	.885	.6151	570	.880	.6082	555	500
600	.813	.985	.7620	690	.980	.7542	675	600
700	.877	1.050	.8659	795	1.050	.8659	780	700
750	.908	1.075	.9076	845	1.090	.9331	830	750
1000	1.060	1.255	1.2370	1100	1.230	1.1882	1085	1000

1 Dimensions are from industry sources.

2 Compact conductor per ASTM B 801. Article 310.14 of the NEC calls for AA 8000 series electrical grade aluminum alloy conductor material.

3 Conductors type THHN, THWN-2 and THWN per UL 83.

4 Conductors type XHHW and XHHW-2 per UL 44.

**Table 5.4 Maximum Number of Aluminum Alloy Building Wire Conductors in Trade Sizes of Conduit or Tubing**

Conductor Size AWG or kcmil	Insulation Type												Conductor Size AWG or kcmil													
	T	T	X	X	T	T	X	X	T	T	X	X		T	T	X	X	T	T	X	X	T	T	X	X	
	H	H	H	H	H	H	H	H	H	H	H	H		H	H	H	H	H	H	H	H	H	H	H	H	
	H	W	H	H	H	W	H	H	H	W	H	H		H	W	H	H	H	W	H	H	H	W	H	H	
Conduit Trade Size (Electrical Metallic Tubing)																										
1		1-1/4		1-1/2		2		2-1/2		3		3-1/2		4												
6	7	6	13	11	18	15																			6	
4	4	4	8	8	11	11	18	18																		4
2	3	3	6	6	8	8	13	13																		2
1			4	4	6	6	10	10	17	17																1
1/0			3	3	5	5	8	8	14	14																1/0
2/0			3	3	4	4	7	7	12	12	18	18														2/0
3/0					3	3	6	6	10	10	15	15														3/0
4/0					3	3	5	5	8	8	12	13	16	17												4/0
250							4	4	6	7	10	10	13	13												250
300							3	3	5	6	8	9	11	11	14	14										300
350							3	3	5	5	7	8	10	10	12	13										350
400									4	4	6	7	9	9	11	11										400
500									4	4	5	6	7	7	9	9										500
600									3	3	4	4	6	6	7	8										600
700											4	4	5	5	7	7										700
750											4	3	5	5	6	6										750
1000											3	3	3	4	4	5										1000

\* Per conduit fill requirements for compact conductors as permitted in NEC Chapter 9.

**Table 5.5 Voltage Drop Calculation for Aluminum Building Wire  
(V-Volts Drop per Amp per 100 Ft.)**

Size AWG or kcmil	Aluminum Conduit					Non-Magnetic and Magnetic Conduit	Steel Conduit				
	Load % Power Factor						Load % Power Factor				
	70	80	90	95	100		DC	70	80	90	95
12	.380	.433	.485	.509	.533	.616	.381	.435	.485	.510	.533
10	.241	.274	.305	.322	.336	.388	.243	.274	.218	.323	.336
8	.153	.174	.193	.203	.211	.244	.155	.176	.195	.204	.211
6	.101	.113	.125	.132	.136	.156	.102	.114	.125	.132	.135
4	.065	.072	.080	.084	.085	.099	.066	.075	.081	.084	.086
2	.043	.047	.051	.053	.054	.062	.044	.048	.052	.054	.053
1	.035	.039	.041	.043	.043	.049	.036	.040	.042	.043	.043
1/0	.029	.032	.034	.035	.034	.039	.030	.033	.035	.035	.034
2/0	.024	.026	.027	.028	.027	.031	.025	.027	.028	.028	.027
3/0	.017	.022	.023	.023	.022	.025	.022	.023	.024	.023	.022
4/0	.016	.017	.018	.018	.017	.020	.017	.018	.018	.018	.017
250	.014	.015	.015	.015	.014	.016	.016	.016	.016	.016	.014
300	.013	.013	.013	.013	.012	.013	.014	.014	.014	.014	.012
350	.012	.012	.012	.011	.010	.012	.013	.013	.013	.012	.010
400	.011	.011	.011	.010	.0089	.010	.012	.012	.012	.011	.0093
500	.0094	.0094	.0091	.0087	.0072	.0082	.011	.010	.010	.0096	.0076
600	.0085	.0085	.0081	.0076	.0060	.0068	.010	.0097	.0090	.0085	.0063
700	.008	.0078	.0072	.0068	.0051	.0059	.0094	.0090	.0084	.0078	.0056
1000	.0068	.0065	.0058	.0053	.0038	.0044	.0082	.0078	.0071	.0064	.0043

All voltage drops are valid up to conductor temperature at 75°C. Compiled from the formula below.

**Voltage Drop Recommendations**

NEC 215.2(A), Fine Print Note No. 2,

*"Conductors for feeders as defined in Article 100, sized to prevent a voltage drop exceeding 3 percent at the farthest outlet of power, heating and lighting loads, or combination of such loads, and where the maximum total voltage drop on both feeders and branch circuits to the farthest outlet does not exceed 5 percent, will provide reasonable efficiency of operation."*

**Table 5.6** **Resistances of Aluminum Alloy Building Wire**  
 (Class B — concentric strands)  
 (Ohms per 1000 feet)

Class B	*	60 Hertz AC -- 60°C		*	60 Hertz AC -- 75°C		*	60 Hertz AC -- 90°C	
		One Single Conductor in Air, Buried, or in Nonmetallic Conduit	Multi-Cond Cable or 2 or 3 Single Conductors in One Metallic Conduit		DC at 60°C	DC at 75°C		One Single Conductor in Air, Buried, or in Nonmetallic Conduit	Multi-Cond. Cable or 2 or 3 Single Conductors in One Metallic Conduit
12	3.08	3.08	3.08	3.24	3.24	3.24	3.41	3.41	3.41
10	1.94	1.94	1.94	2.04	2.04	2.04	2.14	2.14	2.14
8	1.22	1.22	1.22	1.28	1.28	1.28	1.35	1.35	1.35
6	.767	.767	.767	.870	.870	.870	.847	.847	.847
4	.482	.482	.482	.508	.508	.508	.533	.533	.533
3	.383	.383	.383	.403	.403	.403	.423	.423	.423
2	.303	.303	.303	.319	.319	.319	.335	.335	.335
1	.241	.241	.241	.253	.253	.253	.266	.266	.266
1/0	.191	.191	.191	.201	.201	.201	.211	.211	.211
2/0	.151	.151	.151	.159	.159	.159	.167	.167	.167
3/0	.120	.120	.121	.126	.126	.127	.132	.132	.132
4/0	.0952	.0955	.0962	.100	.100	.101	.105	.105	.106
250	.0805	.0807	.0821	.0847	.0849	.0864	.0889	.0891	.0907
300	.0651	.0673	.0684	.0706	.0708	.0720	.0741	.0743	.0756
350	.0576	.0578	.0593	.0605	.0607	.0623	.0635	.0638	.0654
400	.0503	.0506	.0523	.0530	.0533	.0551	.0556	.0559	.0578
500	.0403	.0406	.0427	.0424	.0427	.0449	.0445	.0448	.0472
600	.0336	.0339	.0363	.0353	.0357	.0381	.0371	.0375	.0401
700	.0288	.0292	.0320	.0303	.0307	.0336	.0318	.0322	.0353
750	.0268	.0272	.0300	.0282	.0286	.0316	.0296	.0300	.0332
800	.0252	.0256	.0287	.0265	.0270	.0302	.0278	.0283	.0317
900	.0224	.0229	.0260	.0235	.0240	.0273	.0247	.0252	.0286
1000	.0201	.0206	.0239	.0212	.0218	.0252	.0222	.0228	.0264

\* Resistances calculated from NEC Chapter 9.

**Table 5.7 Reactances of Aluminum Allow Building Wire  
Inductive Reactance to neutral Ohms Per 1000 Feet — 60 Hertz  
Non-Magnetic Conduit**

Conductor Covering Thickness (Insulation + Cover) in Mils										
Size AWG or kcmil	45	60	80	95	100	125	140	155	170	190
12*	.0473	.0517	.0555	.0590						
10*	.0440	.0480	.0516	.0543	.0576					
8	.0410	.0446	.0480	.0507	.0534					
6		.0403	.0431	.0455	.0476	.0497				
4		.0379	.0402	.0422	.0443	.0477				
2		.0356	.0377	.0396	.0414	.0424				
1			.0368	.0381	.0399	.0414	.0429	.0443		
1/0			.0356	.0371	.0389	.0399	.0416	.0427		
2/0			.0348	.0363	.0376	.0389	.0402	.0414		
3/0			.0340	.0354	.0368	.0376	.0391	.0399		
4/0			.0332	.0345	.0356	.0366	.0377	.0386		
250				.0338	.0350	.0359	.0368	.0377	.0389	.0397
300				.0330	.0341	.0350	.0359	.0368	.0379	.0391
350				.0325	.0338	.0343	.0356	.0363	.0373	.0381
400				.0324	.0336	.0341	.0354	.0360	.0369	.0377
500				.0318	.0325	.0332	.0341	.0348	.0356	.0366
600					.0322	.0329	.0336	.0343	.0350	.0357
700					.0318	.0325	.0332	.0338	.0345	.0353
750					.0314	.0321	.0329	.0335	.0342	.0348

**Steel Conduit**

Conductor Covering Thickness (Insulation + Cover) in Mils										
Size AWG or kcmil	45	60	80	95	100	125	140	155	170	190
12*	.0591	.0646	.0694	.0738						
10*	.0550	.0600	.0645	.0685	.0720					
8	.0513	.0558	.0600	.0634	.0667					
6		.0504	.0538	.0568	.0595	.0621				
4		.0474	.0502	.0528	.0553	.0597				
2		.0445	.0471	.0495	.0517	.0532				
1			.0460	.0477	.0499	.0517	.0537	.0553		
1/0			.0445	.0463	.0486	.0499	.0520	.0534		
2/0			.0435	.0454	.0471	.0486	.0502	.0517		
3/0			.0426	.0442	.0460	.0471	.0489	.0499		
4/0			.0415	.0432	.0445	.0457	.0471	.0483		
250				.0423	.0438	.0448	.0460	.0471	.0486	.0496
300				.0412	.0426	.0438	.0448	.0460	.0474	.0489
350				.0406	.0423	.0429	.0445	.0454	.0466	.0477
400				.0405	.0420	.026	.0442	.0450	.0462	.0471
500				.0397	.0406	.0415	.0426	.0435	.0445	.0457
600					.0402	.0411	.0420	.0429	.0438	.0447
700					.0397	.0406	.0415	.0423	.0432	.0441
750					.0393	.0402	.0411	.0418	.0427	.0435

\* SOLID

Note: The values in the above tables are based upon Class B concentric compressed stranded conductors. These values are suitable for use with Class B concentric compact stranded conductors of aluminum building wire products.

# 6. Type AC Aluminum Cables

## 6.1 AC Cable Construction

Type AC cable has 2, 3, or 4 insulated conductors in sizes ranging from 14 AWG - 1 AWG for copper and 12 AWG - 1 AWG aluminum or copper clad alu-

minum. These conductors are individually wrapped with moisture-resistant, fire-retardant paper. The grouped conductors are covered with an armor of interlocking metal tape. Type AC cable is rated up to

**Table 6.1 Aluminum Armored (Type AC) Cable System**

Aluminum Armored Cable System					
AWG Size- No. of Cdr. (Copper)	Type of Circuit Conductor	Minimum External Diameter of Armor	Approximate Weight Per 1000 Feet	Coil Length in Feet	Reel Length in Feet
14-2	THHN Solid	0.389	93	250	1000
14-3		0.406	111	250	1000
14-4		0.436	133	250	1000
12-2	THHN Solid	0.422	112	250	1000
12-3		0.443	140	250	1000
12-4		0.476	167	250	1000
10-2	THHN Solid	0.484	146	250	500
10-3		0.509	189	250	500
10-4		0.551	234	250	500
8-2	THHN Stranded	0.616	216	200	500
8-3		0.652	285	200	500
8-4		0.711	364	200	500
6-2	THHN Stranded	0.692	304	100	500
6-3		0.734	414	100	500
6-4		0.802	530	100	500
4-2	THHN Stranded	0.832	429	100	500
4-3		0.884	613	100	500
4-4		0.971	793	100	500
2-2	THHN Stranded	0.952	636	100	500
2-3		1.014	938	100	500
2-4		1.116	1207	100	500

Listed per UL 4 in accordance with NEC Article 333.  
 Cable tray rated. Used in dry locations only.  
 Permitted for branch circuits and feeders in both exposed and concealed work.  
 Requires saddle or clamp type connector, not a set-screw type connector.

600 volts. Aluminum armored cable is marked “Aluminum Armored.”

See Table 6.1 for typical constructions of AC Cable. There are three types of armored cable:

*TYPE ACT:* Armored cable having 60°C (140°F) conductors with PVC insulation suitable for dry locations.

*TYPE ACTH:* Armored cable having 75°C (167°F) conductors with PVC insulation suitable for dry locations.

*TYPE ACTHH:* Armored cable having 90°C (194°F) type THHN conductors. Where this cable is installed in thermal insulation, its ampacity is limited to that of 60°C (140°F) conductors.

## 6.2 AC Cable Applications

Type AC cable is used primarily for branch circuits and feeders in dry, relatively safe locations.

## 6.3 AC Cable Terminations

Following these steps to connect type AC cable to an outlet box or other enclosure:

- a) Remove the armor using a fine tooth hacksaw or a special tool to cut through a single convolution of armor. The cut piece of armor is then “unscrewed” to remove it from the grouped conductors.
- b) Removing a 7-inch (180-mm) length of armor is usually sufficient for connections within an outlet box. A longer lead may be necessary where entering a panelboard enclosure where the conductor must run for some distance to reach its termination point.
- c) Pull out the paper wrapped around the conductors to make room for the insulating bushing. This is supplied with the cable to protect the conductors from the sharp edge of the cut armor. This bushing must be in place before inserting the cable into the fitting or clamp within the box.

d) Connectors listed for armored cable have an inspection opening so that the insulating bushing can be seen after the fitting has been inserted into the box.

e) Use listed fittings or clamps to attach the armored cable to an outlet box or other enclosure. Outlet boxes are available with built-in clamps. Where standard knockouts are provided in an enclosure, the cable can be secured to these openings with a listed fitting of the proper size. This information will be provided on the fitting carton or packaging.

f) Aluminum armored cable is not permitted to be used with fittings in which the set screw directly contacts the aluminum armor.

## 6.4 AC Cable Supports

The NEC requires that Type AC cable be secured at intervals not exceeding 4-1/2 feet (1.37 meters) by approved staples, straps, hangers, or suitable supporting hardware. In addition, it is required to be secured within 12 inches (305 mm) of every outlet box, junction box, cabinet or fitting.

The NEC allows exceptions to these rules where the cable is fished, where flexibility is necessary and where the cable supplies a lighting fixture or equipment within an accessible ceiling.

## 6.5 Fishing AC Cable

The NEC permits type AC armored cable to be run or fished within the air voids of masonry block or tile walls, where such walls are not located below grade or subject to excessive moisture. For concealed work in finished buildings or finished panels for prefabricated buildings where supporting of the cable is impracticable, it is permissible to fish the cable between access points.

## 6.6 AC Cable Grounding

Type AC cable armor is designed to serve as the equipment grounding conductor for the circuit(s) contained within the cable. To improve armor conductivity, a bond strip of copper or aluminum is placed inside the cable in direct contact with the armor throughout its entire length.

Listed fittings for armored cable provide the necessary conductance to provide an adequate equipment grounding circuit. No termination requirements apply to the internal bond strip. Bend this strip back over the armor so that it is secured under the clamping means applied to the armor.

An additional green insulated equipment grounding conductor may be included with the circuit conductors to provide an isolated ground for data processing equipment or a redundant ground for circuits in health care facilities.

### **6.7 AC Cable Ampacities**

NEC Table 310-16 lists ampacities for Type AC cables. Derating factors apply when more than three current carrying conductors are present in the cable. Correction factors apply when the ambient temperature exceeds 30°C (86°F).

# 7. Type MC Cable

## 7.1 MC Cable Construction

Type MC cable has one or more insulated conductors ranging from 18 AWG (copper) or 12 AWG (aluminum) up to 2000 kcmil. Copper conductors are commonly used in the smaller sizes, while the large-size cables are available with either copper or aluminum conductors. The conductor bundle has an overall wrap of paper or plastic. Standard ratings for MC cable include 600 volts, 2000 volts, and 5000 - 35,000 volts, which are covered under the listing for Type MV.

Type MC cable is available with two types of armor, which may be constructed of either steel or aluminum:

1. Interlocking metal tape, with an integral bare equipment grounding conductor, and
2. Smooth or corrugated tube armor.

Both configurations can also be supplied with an integral insulated grounding conductor.

Table 7.1 provides nominal dimensions and other construction details of Type MC Cable with Type XHHW-2 compact aluminum alloy conductors.

## 7.2 MC Cable Applications

MC cable is permitted, under various NEC Articles, to be used for a wide range of applications including branch circuits, feeders, service lines, control circuit, wet locations, places of public assembly, health care facilities, and certain hazardous locations.

## 7.3 MC Cable Fittings

MC cable fittings have a shoulder to protect the inside conductors from any sharp edge that may be

present on the cut end of the armor. It is important that fittings be listed for use with the particular type of cable with which they are used.

## 7.4 MC Cable Supports

The NEC requires that Type MC cable be supported and secured at intervals not exceeding 6 feet (1.83 meters). Further, cables containing four or fewer conductors, sized no larger than No. 10 are required to be secured within 12 inches (305 mm) of every box, cabinet, fitting, or other cable termination.

The NEC allows exceptions to these rules where the cable is fished, where flexibility is necessary and where the cable supplies a lighting fixture or equipment within an accessible ceiling.

In vertical installations, Type MC cable is typically supported and secured in accordance with the above requirement. Further, it is recommended that an offset be provided in the cable runs at distances similar to those used to support the conductors in raceways for vertical runs. See Table 7.2 for details.

## 7.5 MC Cable Grounding

For Type MC cable the equipment grounding conductor is the combined metallic sheath and all of the grounding conductors furnished in the cable. For smooth or corrugated MC cable without an internal grounding conductor, the armor alone serves as the equipment grounding conductor. If a green insulated conductor is provided within the cable in addition to the required equipment grounding conductor, it may be used to supply an isolated ground for data processing or a redundant ground for health care applications.

(NOTE: NEC Section 517-13(a) Exception No. 1 requires that when listed Type MC cable is used in patient care areas of health care facilities, it shall have

its outer metal armor or sheath identified as an acceptable grounding return path.)

**Table 7.1** Nominal Dimensions and Weights of Aluminum Armored Type MC with XHHW-2 Conductors

Conductor Size (AWG/KCMIL)	Sub-Assembly <sup>1</sup>	Nominal Diameter (Inches)		Length (Feet)	Reel Size		Nominal Mass (Net lbs/mft)		Conductor Size (AWG/KCMIL)
		w/o JKT <sup>2</sup>	JKT <sup>3</sup>		w/o JKT	JKT	w/o JKT	JKT	
<b>THREE CONDUCTOR WITH GROUND</b>									
6-6-6-6	0.63	0.83	0.93	1000	36.22.18	36.22.18	254	336	6
4-4-4-6	0.72	0.93	1.03	1000	36.22.18	36.22.18	326	417	4
2-2-2-6	0.81	1.03	1.13	1000	38.22.20	42.28.20	422	522	2
1-1-1-4	0.94	1.16	1.26	1000	42.28.20	42.28.20	528	641	1
1/0-1/0-1/0-4	1.00	1.23	1.33	1000	42.25.20	42.28.20	610	729	1/0
2/0-2/0-2/0-4	1.05	1.28	1.38	1000	42.28.20	48.28.24	699	823	2/0
3/0-3/0-3/0-4	1.13	1.36	1.46	1000	48.28.24	48.28.24	824	956	3/0
4/0-4/0-4/0-2	1.27	1.51	1.63	1000	60.28.28	60.28.28	1060	1235	4/0
250-250-250-2	1.38	1.63	1.75	500	48.28.30	48.28.30	1225	1414	250
300-300-300-2	1.47	1.72	1.84	500	48.28.30	48.28.30	1400	1599	300
350-350-350-2	1.54	1.80	1.92	500	48.28.30	48.28.36	1571	1780	350
400-400-400-1	1.64	1.91	2.03	500	48.28.30	60.28.30	1762	1983	400
500-500-500-1	1.77	2.04	2.16	500	60.28.36	60.28.36	2099	2335	500
600-600-600-1	1.96	2.24	2.39	500	60.28.36	60.28.36	2500	2758	600
700-700-700-1/0	2.10	2.39	2.54	500	66.32.42	66.32.42	2853	3198	700
750-750-750-1/0	2.15	2.44	2.59	500	66.32.42	66.32.42	3016	3368	750
<b>FOUR CONDUCTOR WITH GROUND</b>									
6-6-6-6-6	0.70	0.92	1.02	1000	36.22.18	38.22.20	303	394	6
4-4-4-4-6	0.77	1.04	1.14	1000	38.22.20	42.28.20	398	499	4
2-2-2-2-6	0.93	1.17	1.27	1000	42.28.20	42.28.20	526	640	2
1-1-1-1-4	1.07	1.31	1.41	1000	42.28.20	48.28.24	655	782	1
1/0-1/0-1/0-1/0-4	1.15	1.40	1.50	1000	48.28.24	48.28.24	765	900	1/0
2/0-2/0-2/0-2/0-4	1.26	1.52	1.64	1000	48.28.24	48.28.24	948	1125	2/0
3/0-3/0-3/0-3/0-4	1.32	1.58	1.70	1000	48.28.24	60.28.28	1107	1294	3/0
4/0-4/0-4/0-4/0-2	1.46	1.73	1.85	1000	60.28.28	60.28.28	1344	1544	4/0
250-250-250-250-1	1.62	1.89	2.01	500	48.28.30	60.28.36	1577	1794	250
300-300-300-300-1	1.73	2.01	2.13	500	60.28.36	60.28.36	1813	2045	300
350-350-350-350-1/0	1.85	2.13	2.25	500	60.28.36	60.28.36	2064	2310	350
400-400-400-400-1/0	1.94	2.23	2.35	500	60.28.36	60.28.36	2299	2547	400
500-500-500-500-2/0	2.13	2.43	2.58	500	60.28.36	60.28.36	2767	3118	500
600-600-600-600-2/0	2.37	2.68	2.83	500	66.32.42	66.32.42	3300	3686	600
700-700-700-700-2/0	2.50	2.83	2.98	500	66.32.42	—	3736	4143	700
750-750-750-750-3/0	2.60	2.93	3.08	500	66.32.42	—	3991	4412	750

1 – Diameter of conductors without armor

2 – Cable without PVC jacket

3 – Cable with PVC jacket over armor

### 7.6 MC Cable Ampacities

NEC Table 310.16 can be used for ampacities for Type MC cables. Derating factors apply where more than three current carrying conductors are present in the cable. Correction factors apply when the ambient temperature exceeds 30°C (86°F).

### 7.7 MC Cable Bending Radius

All bends should be so made that the cable will not be damaged. Minimum radii of the curve of the inner edge of any bend are specified below for different types of aluminum MC cable.

#### 7.7.1 Smooth sheath

- Ten times the external diameter of the metallic sheath for cable not more than 3/4 inch (19 mm) in external diameter;
- Twelve times the external diameter of the metallic sheath for cable more than 3/4 inch (19 mm) but not more than 1-1/2 inches (38 mm) in external diameter; and
- Fifteen times the external diameter of the metallic sheath for cable more than 1-1/2 inches (38 mm) in external diameter.

#### 7.7.2 Interlocked-type armor or corrugated sheath

Seven times the external diameter of the metallic sheath.

#### 7.7.3 Shielded conductors

Twelve times the overall diameter of one of the individual conductors or seven times the overall diameter of the multiconductor cable, whichever is greater.

**Table 7.2 Supporting Conductors in Vertical Raceways\***

		Conductors	
		Aluminum	Copper
18 AWG through 8 AWG	Not greater than	100 feet	100 feet
6 AWG through 1/0 AWG	Not greater than	200 feet	100 feet
2/0 AWG through 4/0 AWG	Not greater than	180 feet	80 feet
Over 4/0 through 350 kcmil	Not greater than	135 feet	60 feet
Over 350 kcmil through 500 kcmil	Not greater than	120 feet	50 feet
Over 500 kcmil through 750 kcmil	Not greater than	95 feet	40 feet
Over 750 kcmil	Not greater than	85 feet	35 feet

\* From 1999 NEC Table 300-19(a)

The 1999 NEC reads as follows: Spacing intervals-maximum. Conductors in vertical raceways shall be supported if the vertical rise exceeds the values in Table 300-19(a). One cable support shall be provided at the top of the vertical raceway or as close to the top as practical. Intermediate support shall be provided as necessary to limit support conductor lengths to not greater than those values specified in Table 300-19(a).

*(This annex is not a part of the standard)*

# Annex A: Reference Standards

This publication, when used in conjunction with the National Electrical Code and manufacturers' literature, provides sufficient information to install aluminum building wire and cable. The following publications may also provide useful information:

American National Standards Institute (ANSI)  
11 West 42nd Street, 13th Floor  
New York, NY 10036  
(212) 642-4900  
(212) 398-0023 fax  
[www.ansi.org](http://www.ansi.org)

ANSI B18.2.1-1981 (R1992), *Square Hex Bolts and Screws – Inch Series*

Association Society for Testing and Materials (ASTM)  
100 Barr Harbor Drive  
West Conshohocken, PA 19428  
(610) 832-9500  
(610) 832-9555 fax  
[www.astm.org](http://www.astm.org)

A325-97, *Standard Specification for Structural Bolts, Steel, Heat Treated, 120/105 ksi Minimum Tensile Strength*

ASTM B11-99, *Standard Specification for Aluminum and Aluminum-Alloy Bar, Rod, and Wire*

ASTM B221-96, *Standard Specification for Aluminum and Aluminum-Alloy Extruded Bars, Rods, Wire, Profiles and Tubes*

Underwriters Laboratories Inc.  
333 Pfingsten Road  
Northbrook, IL 60062-2096 USA  
(847) 272-8800  
(847) 272-8129 fax  
[www.ul.com](http://www.ul.com)

*UL Electrical Construction Equipment Directory*

**Current *National Electrical Installation Standards*™ Published by NECA:**

National Electrical Contractors Association  
3 Bethesda Metro Center, Suite 1100  
Bethesda, MD 20814  
(301) 215-4504 tel, (301) 215-4500 fax  
[www.neca-neis.org](http://www.neca-neis.org)

- NECA 1-2000, *Standard Practices for Good Workmanship in Electrical Contracting* (ANSI)
- NECA 90-2004, *Recommended Practice for Commissioning Building Electrical Systems* (ANSI)
- NECA 100-1999, *Symbols for Electrical Construction Drawings* (ANSI)
- NECA 101-2001, *Standard for Installing Steel Conduits (Rigid, IMC, EMT)*
- NECA 102-2004, *Standard for Installing Aluminum Rigid Metal Conduit* (ANSI)
- NECA/AA 104-2000, *Recommended Practice for Installing Aluminum Building Wire and Cable* (ANSI)
- NECA/NEMA 105-2002, *Recommended Practice for Installing Metal Cable Tray Systems* (ANSI)
- NECA 111-2003, *Standard for Installing Nonmetallic Raceways (RNC, ENT, LFNC)* (ANSI)
- NECA 200-2002, *Recommended Practice for Installing and Maintaining Temporary Electrical Power at Construction Sites* (ANSI)
- NECA 202-2001, *Recommended Practice for Installing and Maintaining Industrial Heat Tracing Systems* (ANSI)
- NECA 230-2003, *Standard for Selecting, Installing, and Maintaining Electric Motors and Motor Controllers* (ANSI)
- NECA/FOA 301-2004, *Standard for Installing and Testing Fiber Optic Cables* (ANSI)
- NECA 303-2005, *Standard for Installing Closed-Circuit Television (CCTV) Systems* (ANSI)
- NECA 305-2001, *Standard for Fire Alarm System Job Practices* (ANSI)
- NECA 331-2004, *Standard for Building and Service Entrance Grounding and Bonding*
- NECA 400-1998, *Recommended Practice for Installing and Maintaining Switchboards* (ANSI)
- NECA 402-2001, *Recommended Practice for Installing and Maintaining Motor Control Centers* (ANSI)
- NECA/EGSA 404-2000, *Recommended Practice for Installing Generator Sets* (ANSI)
- NECA 405-2001, *Recommended Practice for Installing and Commissioning Interconnected Generation Systems* (ANSI)
- NECA 406-2003, *Standard for Installing Residential Generator Sets* (ANSI)
- NECA 407-2002, *Recommended Practice for Installing and Maintaining Panelboards* (ANSI)
- NECA 408-2002, *Recommended Practice for Installing and Maintaining Busways* (ANSI)
- NECA 409-2002, *Recommended Practice for Installing and Maintaining Dry-Type Transformers* (ANSI)
- NECA/IESNA 500-1998, *Recommended Practice for Installing Indoor Commercial Lighting Systems* (ANSI)
- NECA/IESNA 501-2000, *Recommended Practice for Installing Exterior Lighting Systems* (ANSI)
- NECA/IESNA 502-1999, *Recommended Practice for Installing Industrial Lighting Systems* (ANSI)

NECA 503-2005, *Standard for Installing Fiber Optic Lighting Systems*

NECA/BICSI 568-2001, *Standard for Installing Commercial Building Telecommunications Cabling* (ANSI)

NECA/MACSCB 600-2003, *Recommended Practice for Installing and Maintaining Medium-Voltage Cable* (ANSI)

NECA/NEMA 605-2005, *Recommended Practice for Installing Underground Nonmetallic Utility Duct* (ANSI)

*<This page intentionally left blank>*



National Electrical  
Contractors Association  
3 Bethesda Metro Center  
Suite 1100  
Bethesda, MD 20814  
301-657-3110  
fax: 301-215-4500  
[www.neca-neis.org](http://www.neca-neis.org)

**Codes & Standards**  
**Index: NECA 104(R)**  
**1.5K/2-06**



# NEIS